

# PRYMA

## IP67 BOXES FOR INDUSTRIAL SOCKETS

Description: IP67 SURFACE BOX 1x9 MOD. (TW). N&E BARS

Reference:  
**178P/RR**

### Characteristics:

<b>Product type:</b>	Boxes for industrial sockets with neutral and earth bars
<b>Exterior dimensions (Height x Width x Depth):</b>	284x222x122 mm
<b>Dimensions of the flush-fit gap (HxWxD):</b>	-
<b>Number of modules:</b>	1x9 DIN rail
<b>Installation:</b>	Surface
<b>Color:</b>	Grey RAL 7035
<b>Window:</b>	Transparent tinted window
<b>Weight (Kg):</b>	1,3
<b>Cable entry:</b>	-
<b>Components:</b>	-
<b>Materials:</b>	Halogen-free plastic materials. Frame and base: ABS. Transparent window: UV protection polycarbonate

### Technical data:

<b>Degree of protection:</b>	IP67
<b>Resistance to impact:</b>	IK08
<b>Glow wire resistance:</b>	650 °C
<b>Ball pressure test:</b>	70 °C
<b>Ambient temperature range:</b>	-25 °C / +40 °C
<b>Maximum operating voltage:</b>	1000 V AC / 1500 V DC
<b>Double insulation:</b>	Class II

### Certificates and standards:

<b>Directive:</b>	2014/35/EU
<b>Standards:</b>	UNE-EN 62208 and UNE-EN 61439-1 (as applicable)
<b>Certificates:</b>	



### Codes:

<b>EAN:</b>	8431044100029
<b>Customs tariff number:</b>	85.38.10.00
<b>ETIM 6.0:</b>	EC000379

# PRYMA

## IP67 BOXES FOR INDUSTRIAL SOCKETS

Description: IP67 SURFACE BOX 1x9 MOD. (TW). N&E BARS

Reference: 178P/RR

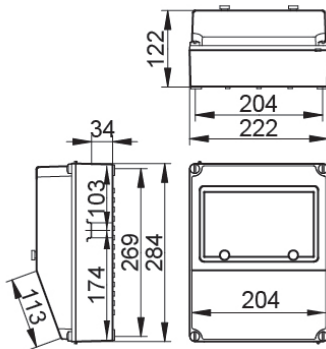

### Detailed drawing:

 <http://www.ide.es/downloads/planos/pdf/178PRR.pdf>

 <http://www.ide.es/downloads/planos/dxf/178PRR.dxf>

 <http://www.ide.es/downloads/planos/stp/178PRR.stp>

### Exterior dimensions (Height x Width x Depth):

284x222x122 mm

### Dimensions of the flush-fit gap (Height x Width x Depth):

-

### Sustainability:

RoHS - REACH

### Supply:

Supplied in individual cardboard packaging. When several items are sent together, they are bundled together with transparent film.

Packaging units: 5

### Product end of life:

It does not require specific recycling operations.

### Recommended applications:

Industrial and outdoor environments. Industrial sites, docks, swimming pools, garages, anywhere that requires a high degree of protection against dust, splashes and impacts.